

**LA-6566-MS**

Informal Report

C. 3

**CIC-14 REPORT COLLECTION  
REPRODUCTION  
COPY**

UC-15

Issued: November 1976

**Sodium Iodide and Plastic Scintillator  
Doorway Monitor Response to  
Shielded Reactor Grade Plutonium**

by

Thomas E. Sampson  
Paul E. Fehlau



**los alamos**  
**scientific laboratory**  
of the University of California  
LOS ALAMOS, NEW MEXICO 87545



An Affirmative Action/Equal Opportunity Employer

This work was supported by the US Energy Research and Development Administration, Division of Safeguards and Security.

Printed in the United States of America. Available from  
National Technical Information Service  
U.S. Department of Commerce  
5285 Port Royal Road  
Springfield, VA 22161  
Price: Printed Copy \$3.50 Microfiche \$3.00

This report was prepared as an account of work sponsored by the United States Government. Neither the United States nor the United States Energy Research and Development Administration, nor any of their employees, nor any of their contractors, subcontractors, or their employees, makes any warranty, express or implied, or assumes any legal liability or responsibility for the accuracy, completeness, or usefulness of any information, apparatus, product, or process disclosed, or represents that its use would not infringe privately owned rights.

SODIUM IODIDE AND PLASTIC SCINTILLATOR  
DOORWAY MONITOR RESPONSE TO  
SHIELDED REACTOR GRADE PLUTONIUM

by

Thomas E. Sampson and Paul E. Fehlau

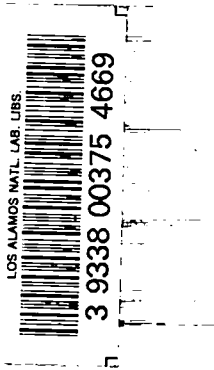

ABSTRACT

We present the results of measurements to determine the response of typical doorway monitors to heavily shielded reactor-grade plutonium. These measurements were made to aid the Brookhaven National Laboratory in their study of the feasibility of spiking nuclear fuels for safeguards purposes.

The largely unevaluated raw data presented consist of the following:

- 1) Point source gamma-ray efficiency measurements for the two types of Los Alamos portal monitors.
- 2) Point neutron source count rates in the same monitors.
- 3) Broad-beam attenuation measurements with lead shielding on several Pu and PuO<sub>2</sub> samples.
- 4) Count rates in the Los Alamos portal monitor from lightly Pb-shielded PuO<sub>2</sub> sources.
- 5) Gamma-ray spectral data from the Pu and PuO<sub>2</sub> sources taken with a 12.7-cm-diam by 2.5-cm-thick NaI detector and also a Ge(Li) detector.
- 6) Gamma-ray dose rate versus distance from unshielded PuO<sub>2</sub> sources.
- 7) Relative neutron detector count rate as a function of polyethylene shielding thickness around an isotopic PuLiF neutron source.

## I. INTRODUCTION

The Los Alamos Scientific Laboratory (LASL) has been engaged in design, development, and evaluation of personnel doorway monitors for detection of special nuclear materials (SNM) for the past several years. Early LASL work in this area was documented in a report "Portal Monitor for Diversion Safeguards," LA-5681, December 1974. At the time that report probably represented the most complete documentation of portal monitor principles and performance that was widely available.

Because the characteristics of the LASL portal monitor were well documented, in June of 1975 we were asked by E. V. Weinstock of the Technical Support Organization of Brookhaven National Laboratory (BNL) to perform some measurements of the sensitivity of our portal monitors to high burnup plutonium. These measurements were to provide BNL with data to use in a Nuclear Regulatory Commission (NRC) study on the spiking of nuclear fuels for safeguards purposes.

A limited set of measurements using readily available samples was undertaken on a no-cost basis for BNL. The results of these measurements were supplied to BNL in the form of unevaluated raw data so that BNL could arrive at their own conclusions and interpretations.

This report will serve to document the results of these measurements. The data will be presented in much the same fashion as they were furnished to BNL, that is, largely unevaluated raw data. The reader is cautioned to use care and judgement in applying or extrapolating these results to other conditions.

Details of the construction and operation of the portal monitors used in these tests are to be found in LA-5681 and will not be repeated here. This report should be considered as a supplement to LA-5681.

## II. POINT SOURCE GAMMA-RAY EFFICIENCY FOR LASL PORTAL MONITORS

Count rates from calibrated point source gamma emitters were recorded for both monitors.

### A. NaI Doorway Monitor

- |                 |   |   |
|-----------------|---|---|
| Source Position | - | Calibrated point source placed on centerline of monitor 91.4 cm above the floor. Vertical side separation is 70 cm. Count rate at other heights on vertical centerline can probably be inferred from scan data on page 22 of LA-5681. |
| Energy Range    | - | All counts above a discriminator bias set just above noise (about 10 keV) were recorded.  |

Our calculations for the activity of the principal gamma rays from some of the sources in this set are shown in Table I for the date on which the NaI doorway monitor measurements were made.

TABLE I  
Calibration Source Data

Cal. Date 4/01/74 Amersham Set #279		6/10/75 Activity		
Source	Cal. Act. ( $\mu\text{Ci}$ )	Energy (keV)	Gamma/Sec	% Error
<sup>241</sup> Am	12.43	26.345	11333.	8.2
<sup>241</sup> Am	12.43	59.537	164742.	2.4
<sup>57</sup> Co	11.62	14.41	13112.	4.4
<sup>57</sup> Co	11.62	122.061	120908.	1.6
<sup>57</sup> Co	11.62	136.471	15752.	3.1
<sup>22</sup> Na	11.69	511.0034	564997.	1.3
<sup>22</sup> Na	11.69	1274.511	313734.	1.3
<sup>137</sup> Cs	10.36	661.638	319149.	1.4
<sup>54</sup> Mn	12.31	834.827	174613.	1.3
<sup>60</sup> Co	10.84	1173.208	344850.	0.7
<sup>60</sup> Co	10.84	1332.464	345264.	0.7
<sup>88</sup> Y	10.63	511.0034	95.	5.7
<sup>88</sup> Y	10.63	898.021	21836.	2.8
<sup>88</sup> Y	10.63	1836.03	23771.	2.7
<sup>88</sup> Y	10.63	2734.17	148.	7.0

The net count rates from selected sources from set No. 279 are listed in Table II.

TABLE II

## NaI Doorway Monitor Count Rate

<u>Source</u>	<u>Net Count Rate (cps)</u>
<sup>241</sup> Am	781.6 ± 4.7
<sup>57</sup> Co	742.5 ± 4.6
<sup>137</sup> Cs	1090.1 ± 4.8
<sup>54</sup> Mn	500.3 ± 4.5
<sup>22</sup> Na	2693.7 ± 5.5
<sup>60</sup> Co	1787.6 ± 5.1
<sup>88</sup> Y	118.3 ± 4.2

Background count rate = 2339.5 ± 2.4 cps in a nominal 25- $\mu$ R/h environment.

## Comments:

1. Recorded count rates are static measurements for the one described position only.
2. Some of the sources emit more than one photon per decay. All photons and their different energies must be taken into account when using these data to derive an "efficiency." For this reason we have not tabulated the results in this manner.
3. The source and background count rates correspond to an energy range from just above noise to  $\infty$ . This is not necessarily the optimum energy range to maximize detection sensitivity for any of these sources.
4. Detectability calculations must also include the fact that the source moves through the portal at walking speed.

B. Plastic Scintillator Doorway Monitor

## Source Position

- Calibrated point source placed on centerline of monitor 91.4 cm above the floor. Vertical side separation is 70 cm. Count rate at other heights on the vertical centerline can probably be inferred from scan data on page 22 of LA-5681.

Energy Range

- All counts above a discriminator setting of about 70 mV were recorded. On this same voltage scale the half heights of the Compton edges of several gamma rays are noted below (Table III).

TABLE III

Plastic Scintillator Energy Calibration

<u>Isotope</u>	<u>Energy (keV)</u>	<u>Compton Edge Half Max Pos. (volts)</u>
$^{22}\text{Na}$	1275	6.6
$^{137}\text{Cs}$	662	2.9
$^{60}\text{Co}$	1173}	6.3
	1332}	

Data for calibrated sources for the plastic scintillator doorway monitor are the same as in Table I for NaI measurements.

Our calculation for the activity of the principal gamma rays from the sources that were used are shown in Table IV for the date on which the plastic scintillator doorway monitor measurements were made.

TABLE IV

## Calibration Source Data

<u>Source</u>	Cal. Date 4/01/74 Amersham Set #279		6/10/75 Activity	
	<u>Cal. Act. (<math>\mu</math>Ci)</u>	<u>Energy (keV)</u>	<u>Gamma/Sec</u>	<u>% Error</u>
$^{57}\text{Co}$	11.62	14.41	13834.	4.4
$^{57}\text{Co}$	11.62	122.061	127565.	1.6
$^{57}\text{Co}$	11.62	136.471	16619.	3.1
$^{137}\text{Cs}$	10.36	661.638	319575.	1.4
$^{54}\text{Mn}$	12.31	834.827	182936.	1.3
$^{60}\text{Co}$	10.84	1173.208	347465	0.7
$^{60}\text{Co}$	10.84	1332.464	347883	0.7
$^{88}\text{Y}$	10.63	511.0034	109.	5.6
$^{88}\text{Y}$	10.63	898.021	25006.	2.7
$^{88}\text{Y}$	10.63	1836.03	27222.	2.6
$^{88}\text{Y}$	10.63	2734.17	170.	7.0

The net count rates from selected sources from set No. 279 are listed in Table V.

TABLE V

## Plastic Scintillator Doorway Monitor Count Rate

<u>Source</u>	<u>Net Count Rate (cps)</u>
$^{57}\text{Co}$	1349.2 $\pm$ 7.8
$^{137}\text{Cs}$	3838.0 $\pm$ 9.0
$^{54}\text{Mn}$	1989.8 $\pm$ 6.0
$^{60}\text{Co}$	6942.0 $\pm$ 0.4
$^{88}\text{Y}$	519.2 $\pm$ 5.2



Background count rate =  $4263.9 \pm 3.8$  cps in a nominal 25- $\mu$ R/h environment.

Comments:

1. Recorded count rates are static measurements for the one described position only.
2. Some of the sources emit more than one photon per decay. All photons and their different energies must be taken into account when using these data to derive an "efficiency." For this reason we have not tabulated the results in this manner.
3. The source and background count rates correspond to an energy range from just above noise to  $\infty$ . This is not necessarily the optimum energy range to maximize detection sensitivity for any of these sources.
4. Detectability calculations must also include the fact that the source moves through the portal at walking speed.

III. NEUTRON SOURCE COUNT RATES FOR PLASTIC SCINTILLATOR AND NaI SCINTILLATOR DOORWAY MONITORS

Count rates from heavily gamma-ray shielded isotopic neutron sources were recorded with both doorway monitors. Results are shown in Table VI. Neutron source characteristics are tabulated in Table VII.

Experimental Conditions - Neutron source placed 91.4 cm above the floor on centerline of doorway monitor. Source shielded on all sides by 5.1 cm of lead. Counts recorded above a lower level discriminator set just above noise for both monitors.

TABLE VI

Neutron Source Count Rates

Source	Net Count Rate (cps)	
	Plastic	NaI
PuLiF	11 158 $\pm$ 9	658.0 $\pm$ 4.5
Am-Li	61.6 $\pm$ 5.6	24.3 $\pm$ 4.2
Am-F	64.4 $\pm$ 5.6	17.9 $\pm$ 4.2
Am-B	93.6 $\pm$ 5.6	14.1 $\pm$ 4.1
Am-Be	82.9 $\pm$ 5.6	18.2 $\pm$ 4.2
Background	4 077 $\pm$ 3	2 230 $\pm$ 2

Comments:

1. Even though the neutron sources were heavily gamma-ray shielded, it would be difficult to extract a direct neutron count rate component from the total net count rate listed above. The neutrons from the source produce gamma rays in all the surrounding materials by inelastic scattering and capture. The counts from these neutron-produced gamma rays, direct neutron interactions in the detector, and source gamma rays transmitted through the Pb shielding are all included in the above count rates.

TABLE VII

Neutron Source Data

<u>Source Type</u>	<u>Active Material</u>	<u>Target</u>	<u>Calibration</u>	<u>6/20/75 Source Strength (n/s)</u>
PuLiF	$^{238}\text{Pu}$ $\sim 1.2\text{g}$	$\sim 1.4\text{g Li}_2^{16}\text{O}$ + fluorine contamination	$5.73 \pm 1.3\% \times 10^5 \text{ n/s}$ NBS manganese bath 1 March 1972	$5.56 \times 10^5$
Am-Li	$\sim 17\text{mg AmO}_2$ ( $\sim 50\text{mC}$ )	$\sim 1.4\text{g LiH}$	$1752 \pm 3\% \text{ n/s}$ LASL graphite pile 13 October 1973	1752
Am-F	$\sim 5\text{mg AmO}_2$ ( $\sim 15\text{mC}$ )	$4.14\text{g CaF}_2$	$2220 \pm 4\% \text{ n/s}$ LASL graphite pile 7 September 1973	2220
Am-B	$\sim 1\text{mg AmO}_2$ ( $\sim 4\text{mC}$ )	$3.14\text{g B}$	$3353 \pm 3\% \text{ n/s}$ LASL graphite pile 3 October 1973	3353
Am-Be	$< 1\text{mg AmO}_2$ ( $\sim 1\text{mC}$ )	$2.5\text{g Be}$	$2856 \pm 3\% \text{ n/s}$ LASL graphite pile 6 February 1974	2856

#### IV. BROAD-BEAM ATTENUATION MEASUREMENTS ON Pu SAMPLES

Broad-beam attenuation measurements were carried out to enable one to estimate the doorway monitor count rate from a wide range of Pb-shielded Pu samples. Attenuation measurements as a function of Pb thickness were made for five Pu samples in the geometry of Fig. 1 using a 12.7-cm-diam by 2.5-cm-thick NaI detector. All counts above a lower level discriminator set at 30 keV were recorded. The characteristics of the Pu samples are tabulated in Table VIII. For the two 1-g samples, the source-to-detector face separation was 23 cm. For the three larger PuO<sub>2</sub> samples, this separation was 84 cm. The 12.7-cm-diam by 2.5-cm-thick NaI detector is the same size as the detectors in the NaI doorway monitor.

In addition to the indicated Pb thickness, note that the front face of the NaI detector was shielded with 0.8 mm of Cd. This filtered the 60-keV <sup>241</sup>Am gamma ray and enabled zero Pb-thickness measurements to be made with the smaller samples without overloading the counting electronics.

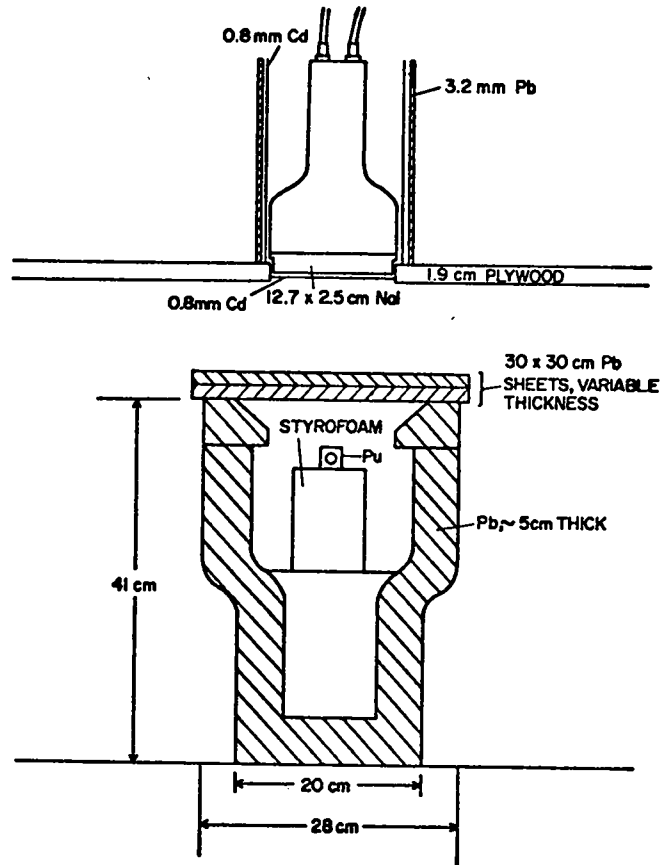

Fig. 1.  
Geometry of Broad-Beam Attenuation Measurements on Pu Samples.

Figures 2 and 3 display the results of the broad-beam attenuation measurements. The data begin to saturate when the variable lead thickness approaches the 5-cm thickness of the rest of the shielding around the sample. Scattering from gamma rays transmitted through the 5-cm-Pb thickness then begins to dominate. To deduce count rates in the doorway monitor for the three larger  $\text{PuO}_2$  samples, one should use these attenuation curves (Figs. 2, 3) coupled with the count rates in the doorway monitors for lightly shielded samples presented in the next section.

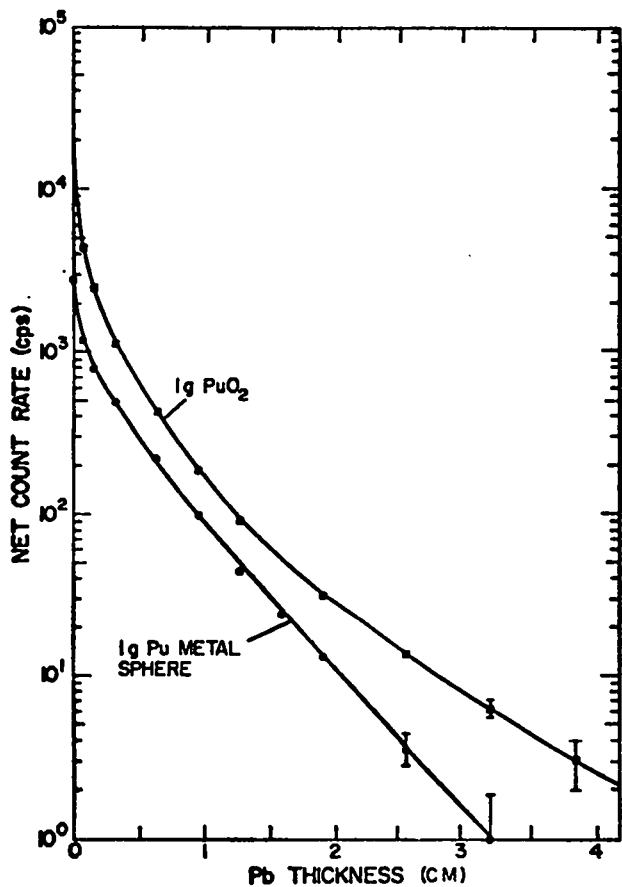

Fig. 2.  
Broad-Beam Attenuation  
from 1g Pu Samples.

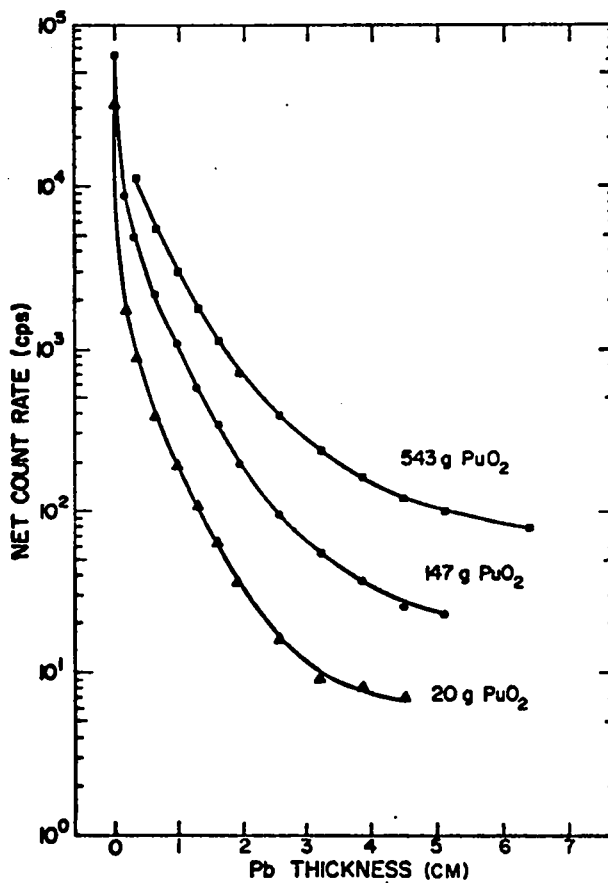

Fig. 3.  
Broad-Beam Attenuation  
from PuO<sub>2</sub> Samples.

TABLE VIII

## Characteristics of Plutonium Samples Used in Doorway Monitor Tests

Sample	Total Mass (g)	Pu Isotopic Analysis (Atom %)					<sup>241</sup> Am	Physical Characteristics
		238	239	240	241	242		
1g sphere	1.0656	0.016	93.56	5.92	0.462	0.033	189ppm 7/25/74	Metal sphere, density 19.62g/cm <sup>3</sup> , diam 4.71mm, encapsulated in cylindrical stainless steel can with 0.4mm-thick walls.
1g PuO <sub>2</sub>		0.148	81.36	15.11	2.72	0.657	5150ppm 3/13/73	~1g Pu as PuO <sub>2</sub> , doubly encapsulated in cylindrical plastic vials with overall outside dimensions, 20mm diam by 55mm high.
543g	543g Pu as PuO <sub>2</sub>	0.016	79.309	18.796	1.547	0.333	12200ppm 6/12/75	PuO <sub>2</sub> doubly encapsulated in cylindrical "tin cans." Dimensions of outer cans are 10.8cm diam by 12.4cm high. Inner cans are about 8.7cm diam by 12cm high. Because of large cans, PuO <sub>2</sub> geometry is not compact, especially for 147g and 20g samples.
147g	147g Pu as PuO <sub>2</sub>	0.013	83.371	15.173	1.201	0.243	3710ppm 6/12/75	
20g	20g Pu as PuO <sub>2</sub>	0.017	77.446	20.446	1.719	0.371	12500ppm 6/12/75	

V. DOORWAY MONITOR COUNT RATES FROM LIGHTLY SHIELDED PuO<sub>2</sub> SAMPLES

Static count rates from the three largest PuO<sub>2</sub> samples shielded by 0.635-cm Pb were measured in both the NaI and plastic scintillator doorway monitors. The results are given in Table IX. The 4 $\pi$  Pb-shielded samples were placed on the doorway centerline 91.4 cm above the floor. Two window conditions were used:

1. Pu window - about 30 to 460 keV for NaI; about 10 mV to 0.9 V for plastic on scale where peak of Compton edge for 511 keV is about 1.3 V. These correspond to near optimum windows for detecting unshielded Pb samples.
2. Wide open - 30 keV to  $\infty$  for NaI  
- just above noise to  $\infty$  for plastic

TABLE IX

DOORWAY MONITOR COUNT RATES FROM LIGHTLY SHIELDED  
(0.635-cm Pb) PuO<sub>2</sub> SAMPLES

<u>Sample</u>	<u>Window</u>	<u>Net cps</u>	
		<u>NaI</u>	<u>Plastic</u>
543g PuO <sub>2</sub>	Pu	11 223 ± 25	————
	Wide open	13 443 ± 28	41 266 ± 48
147g PuO <sub>2</sub>	Pu	5 555 ± 19	10 928 ± 26
	Wide open	6 154 ± 20	18 330 ± 33
20g PuO <sub>2</sub>	Pu	981 ± 12	2 106 ± 16
	Wide open	1 080 ± 14	3 420 ± 20
Background	Pu	1 758 ± 4	2 588 ± 5
	Wide open	2 184 ± 5	4 092 ± 6

The shielded count rates for the two 1-g samples were not recorded because the unshielded 1-g Pu metal sphere is near the limit of detectability for most portal monitors, typically a few tenths of a gram.

## VI. NaI GAMMA-RAY SPECTRAL DATA FROM Pu SAMPLES

For all five Pu samples (Table VIII), gamma-ray spectra were taken with a 12.7-cm-diam by 2.5-cm-thick NaI detector with the detector shielded by 3.2 mm Pb and 0.8 mm Cd. The detector and its Pb shielding thickness are the same as that used in the NaI doorway monitor. In addition, the front face of the detector was covered with 0.8 mm Cd to filter the intense 60-keV <sup>241</sup>Am gamma ray from these sources. This filter has little effect on the remainder of the spectrum.

The sample and detector geometry is shown in Fig. 4. The distance, D, was 61 cm for the two 1-g samples and 3.05 m for the three large PuO<sub>2</sub> samples. Counting time for all spectra was 2000 seconds.

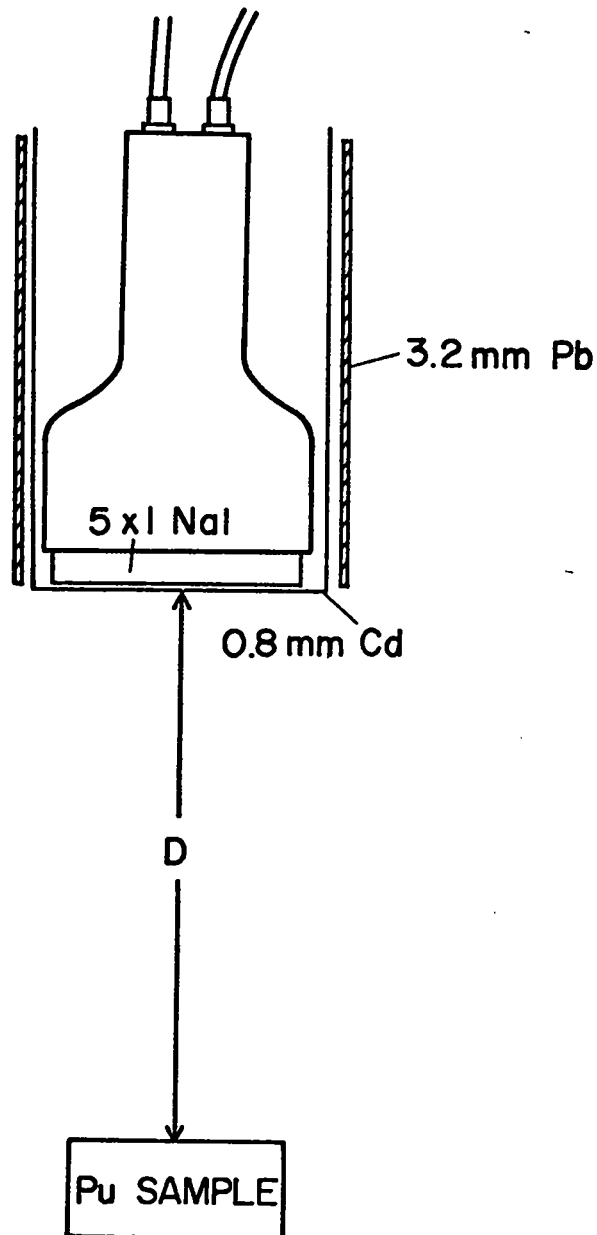

Fig. 4.  
 Geometry for Spectral Measurements  
 on Bare Pu and PuO<sub>2</sub> Samples.  
 D = 61 cm for 1g Pu Metal and 1g PuO<sub>2</sub>.  
 D = 3.05 m for 20, 147, 543g PuO<sub>2</sub>.

Figure 5 shows the background spectrum for the detector-shielding combination used. The energy calibration for this and all the other NaI spectra (Figs. 6-10) is 2 keV/Channel. The spectra from the five Pu sources listed in Table VIII are shown in Figs. 6-10.

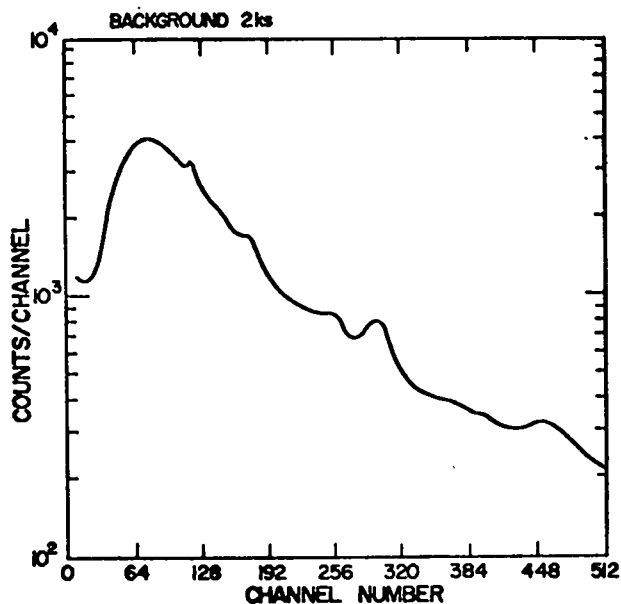

Fig. 5.

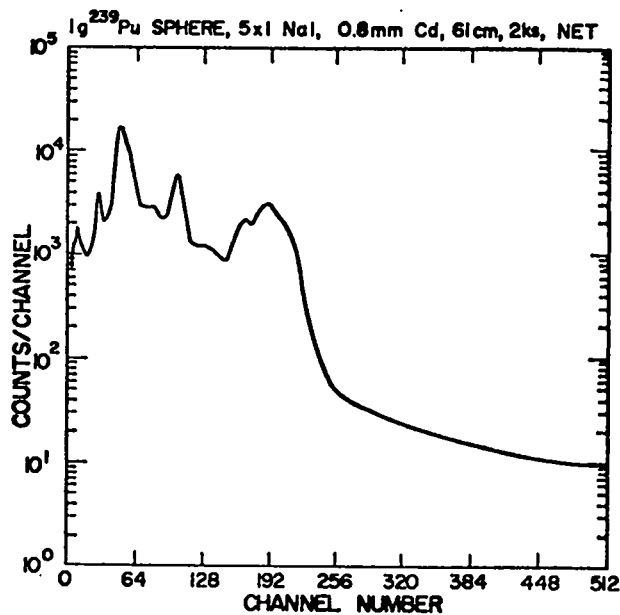

Fig. 6.

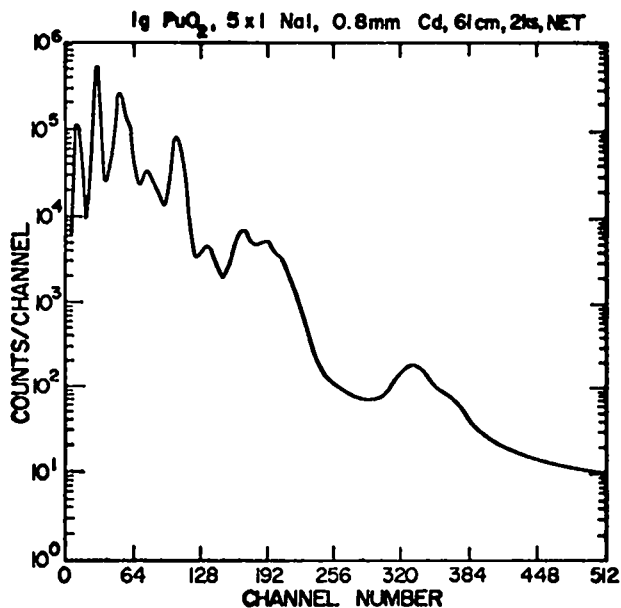

Fig. 7.

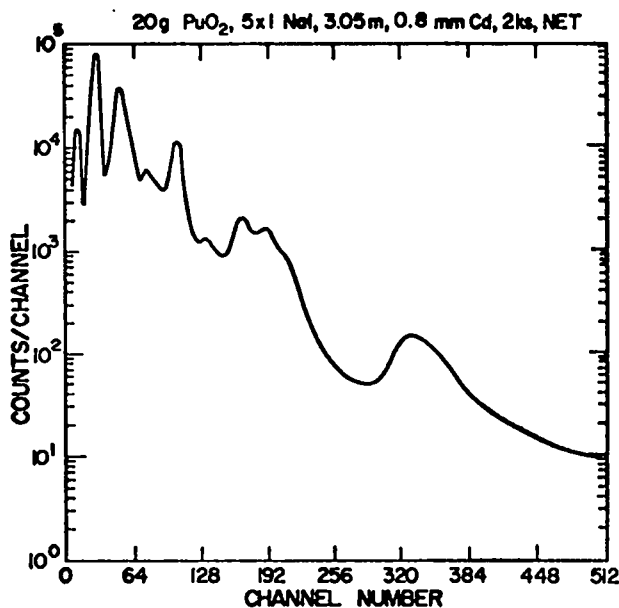

Fig. 8.



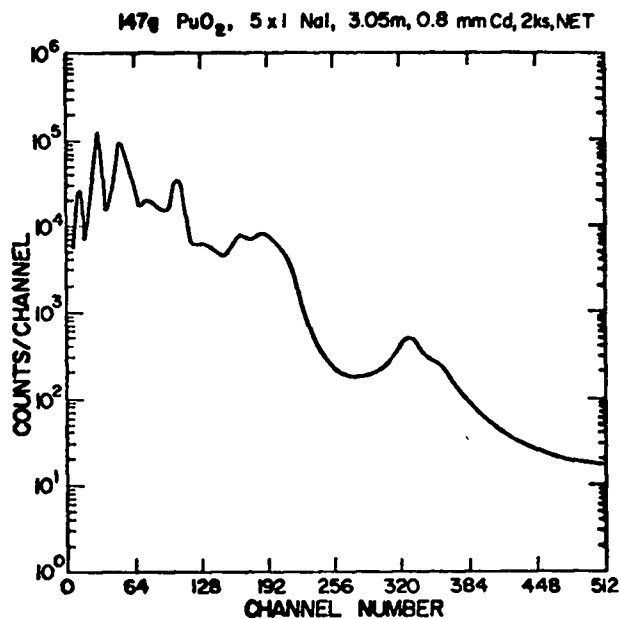

Fig. 9.

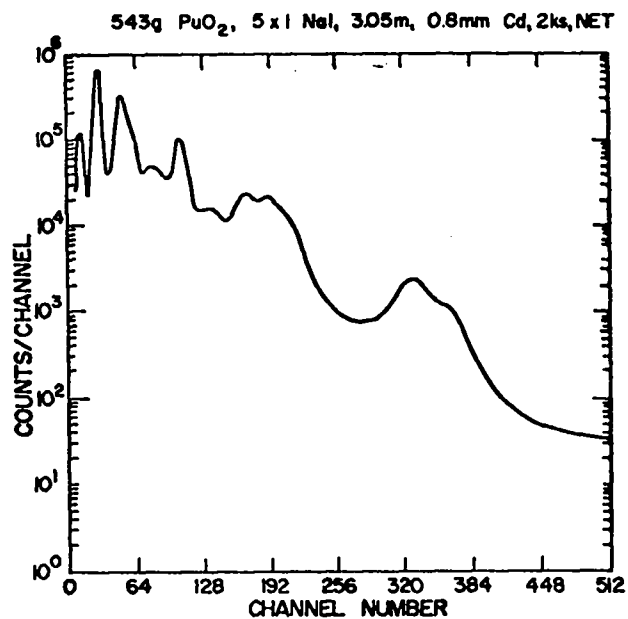

Fig. 10.

Figs. 5-10.

NaI gamma-ray spectral data from Pu samples. 12.7-cm-diam by 2.5-cm-thick NaI detector filtered with 0.8 mm Cd energy calibration is 2 keV/channel. Count time - 2000 seconds. Source and distance description above each graph.



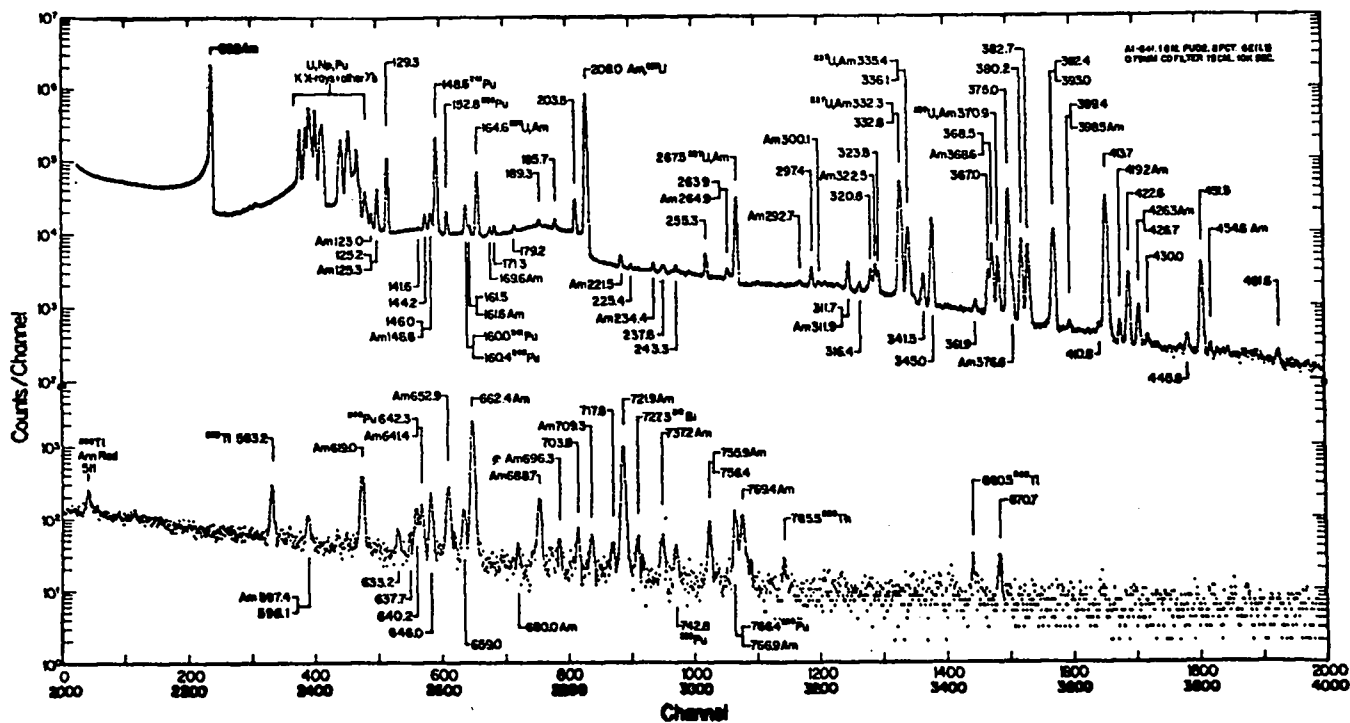

Fig. 12. 1-g PuO<sub>2</sub>, 8% Ge(Li) with 0.8-mm Cd filter. Source distance is 15 cm. Count time is 10<sup>4</sup> seconds.

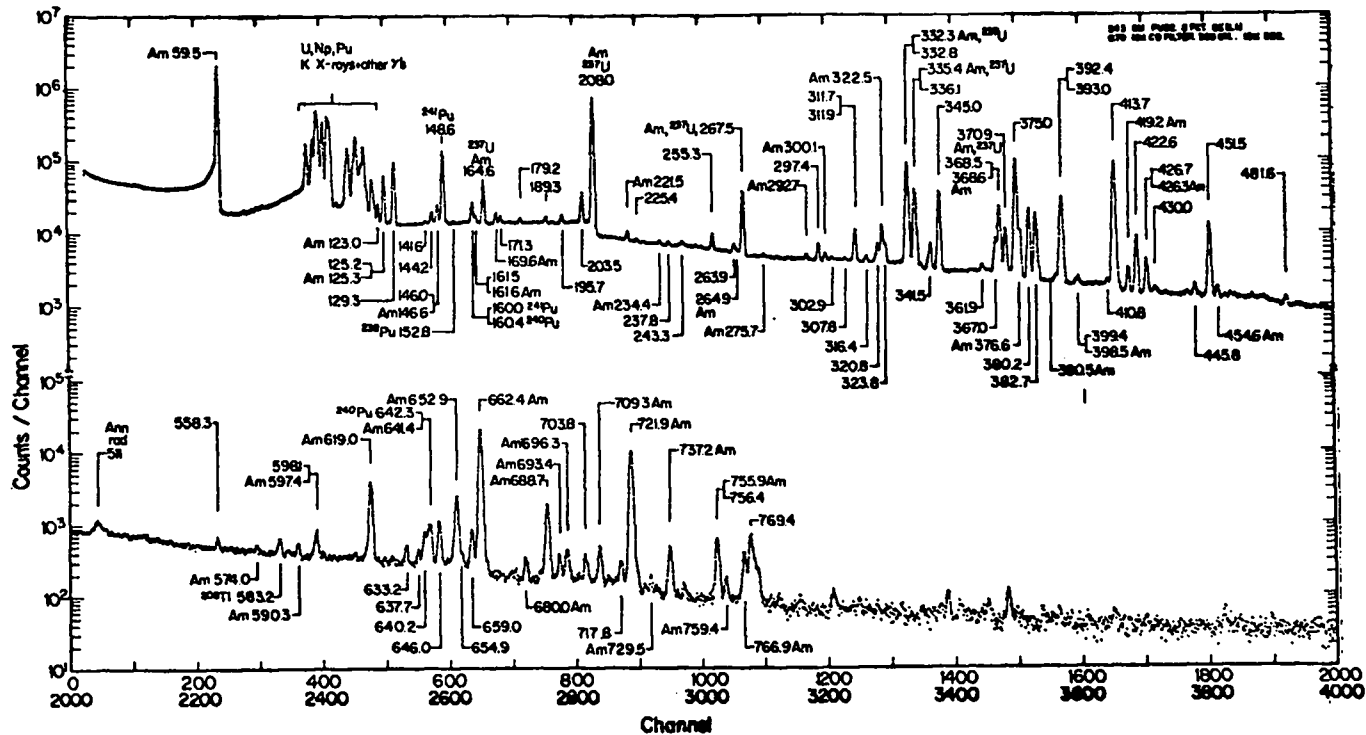

Fig. 13. 543g PuO<sub>2</sub>, 8% Ge(Li) with 0.8-mm Cd filter. Source distance is 1 m. Count time is 10<sup>4</sup> seconds.

### VIII. GAMMA-RAY DOSE RATE FROM PuO<sub>2</sub> SAMPLES

A Victoreen model 440 survey meter was used to measure dose rates as a function of distance from the four PuO<sub>2</sub> samples. Most of the dose rate comes from the <sup>241</sup>Am in the sources. No filters were used in these measurements that are shown in Fig. 14.

Because of the low <sup>241</sup>Am content of the 1-g metal sphere, its dose rate was much lower than any of the PuO<sub>2</sub> samples. It is not plotted in Fig. 14.

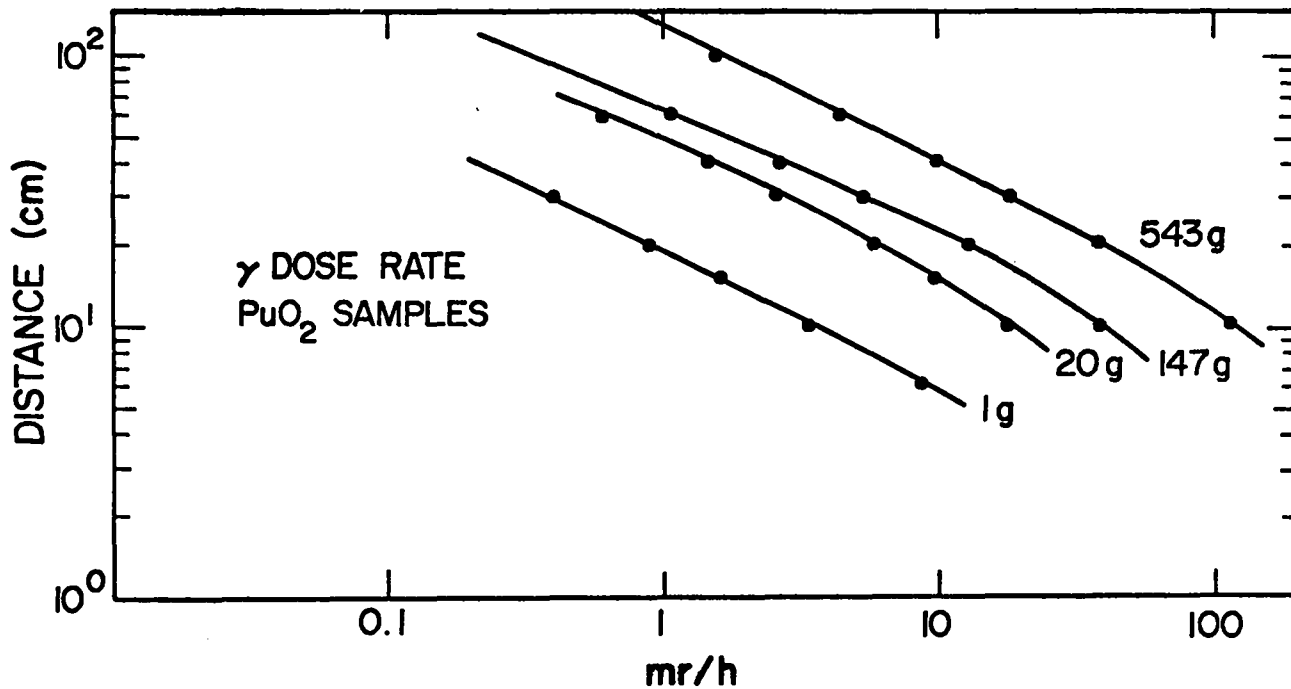

Fig. 14. Gamma-Ray Dose Rate from PuO<sub>2</sub> Samples.

## IX. EFFECT OF SOURCE SHIELDING ON COUNT RATE FROM A MODERATED BF<sub>3</sub> COUNTER

Because high burnup Pu is a strong neutron source, the possibility exists that a neutron doorway monitor may be a useful safeguards device for this material. No such monitor presently exists, but we made some measurements on a single BF<sub>3</sub> detector to investigate the effect of source shielding on the BF<sub>3</sub>-detector count rate.

The measurement conditions are given below. Figure 15 gives the results. No attempt was made to optimize the detector moderator configuration.

Detector: Harshaw type B4-72S/50 BF<sub>3</sub> detector  
Fill pressure: 50-cm Hg  
Active length: 191 cm  
Active diameter: 14.6 cm  
Moderator: 2-cm polyethylene

Source Distance: 3.05 m  
Source Type: PuLiF,  $\bar{E}_n \approx 1$  MeV (see also first entry in Table VII)  
Source Moderator: Polyethylene, variable thickness, with and without Cd covering

### Comments:

1. Detector with 2-cm moderator is undermoderated for bare source spectrum. Count rate attenuation with polyethylene source shielding is relatively small, considering the size of the shielding package that can be hidden on the person.

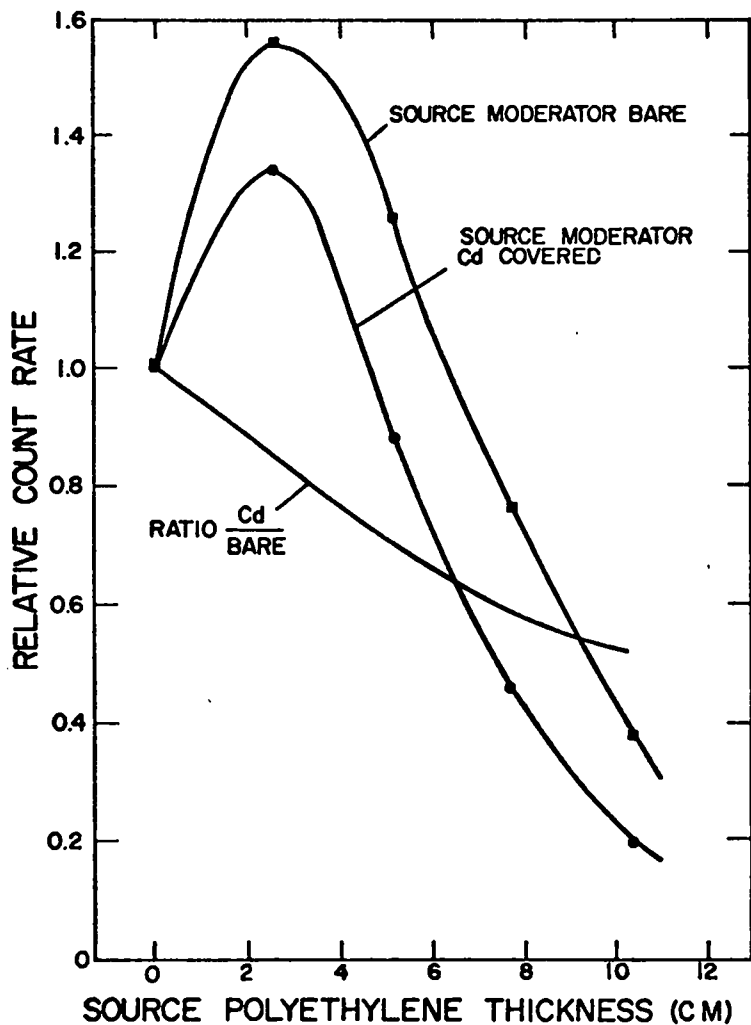

Fig. 15. Effect of Source Moderator on Count Rate in  $\text{BF}_3$  Detector.  
 Source:  $\text{PuLiF}$ ,  $\bar{E}_n \approx 1 \text{ MeV}$ .

CONCLUSION

We have presented the results of measurements of doorway monitor static count rates for various gamma-ray, neutron, and  $\text{PuO}_2$  sources. Careful use of these data can enable one to predict approximate doorway monitor sensitivities to shielded high burnup plutonium.